

MANDATORY SERVICE BULLETIN

MSB09-8A

Subject Matter of This Service Bulletin may be incorporated in whole or in part in an FAA Issued Airworthiness Directive

Supersedes MSB09-8

**Technical Portions
FAA Approved**

- Subject:** Inspection and Removal of Certain TCM Engine Hydraulic Lifters
- Background:** Teledyne Continental Motors, Inc. (TCM) has verified several instances of rapid wear on the surface of hydraulic lifter units (tappets) both in new and rebuilt engines and hydraulic lifter units sold as spares beginning on 19 June 2009. TCM is investigating the cause of the rapid wear and has seen it as early as five hours of engine operation after installation. Loss of engine power and a potential safety of flight issue can result.
- TCM obtains its lifters from an outside supplier. In June of 2009, this supplier released for production new part number lifters made from castings from a different foundry. To distinguish the change in casting source, these parts were assigned new part numbers. Specifically, 657913, 657915 and 657916 part numbers were produced using castings from the new source. Hydraulic lifters designated by part numbers 653877, 653888, and 653906 and earlier (lower) part numbers are not affected by this Mandatory Service Bulletin (MSB).
- Purpose:** Identification of TCM engines assembled (new, overhauled, rebuilt, or repaired) with hydraulic lifters identified by part numbers 657913, 657915, and 657916 and removal of those lifters from service.
- Compliance:** Before further flight of any aircraft using TCM engine models with serial numbers listed in Section A, and engines, overhauled, or repaired with TCM lifters, part number 657913, 657915 or 657916.
- Models Affected:** All TCM 240, 346, 360, 470, 520 and 550 direct drive engines, GIO 550, and GTSIO 520 engines. All Rolls Royce engine models; 240, 360, 470, TCM new and rebuilt engines affected are listed in Section A.
- Any field overhauled or repaired engine with TCM lifters 657913, 657915 and 657916 installed. Engine repaired with components obtained since 19 June, 2009 are suspect and must be inspected. Note these lifters are also used in Cam and Lifter EQ Kits part numbers EQ6994, EQ6995, EQ7002, EQ7003, EQ7068, EQ7079, EQ7081 EQ7082, EQ7067, EQ7080, EQ7473, EQ7474, EQ 7071, EQ7072, EQ7073, EQ7074, EQ 7075, EQ7076, EQ7077, EQ7078, EQ7136, EQ7137.

ISSUE DATE	REVISION DATE	 PO BOX 90, Mobile, AL 36601 251-438-3411	PAGE NO	REVISION
03 Nov 2009	04 Dec 2009			1 of 19
			MSB09-8	

I. ACTION REQUIRED

For engine serial numbers listed in Section A or engines with full cam and lifter EQ kits installed, purchased after 19 June 2009:

1. Remove all intake lifters according to the Hydraulic Lifter Removal instructions in Section B. The part numbers are either laser-etched or stamped (Figure 1) on the oil transfer groove on the lifter body. Inspect each lifter to identify the part number.

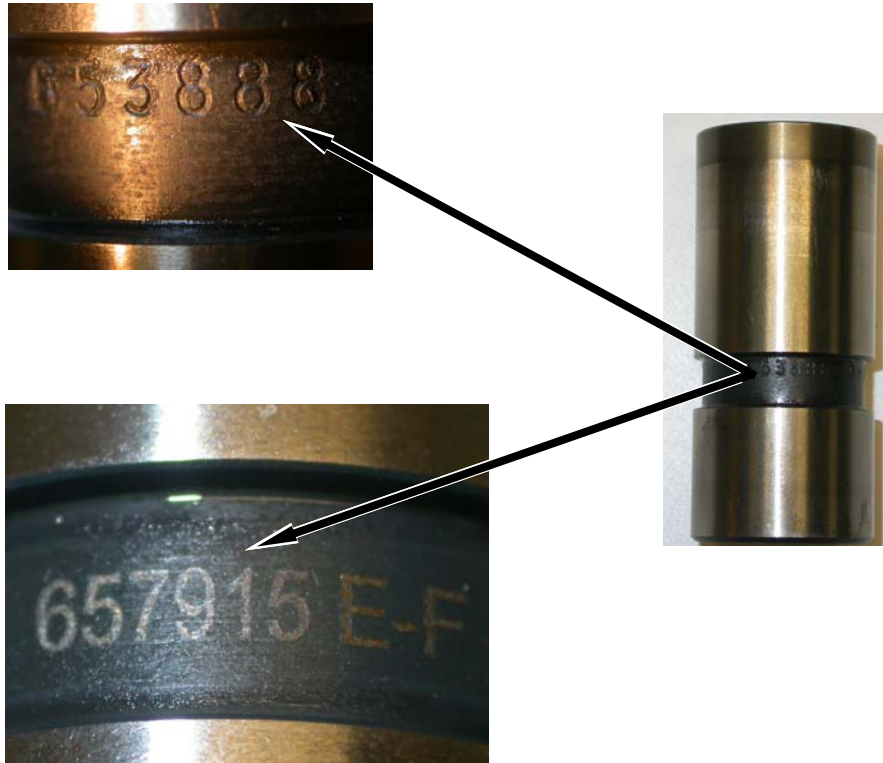



Figure 1. Lifter Part Number Identification

Affected Engine Series	Installed Position	Lifter Part Number	Suitable Replacement Part Number	
			Previous	New
240	Intake and Exhaust	657916	653906	658027
360	Intake and Exhaust	657916	653906	658027
-470, -520, -550	Intake	657915	653888 or 628488	658026
-470, -520, -550	Exhaust	657913	653877 or 646277	658024

2. If only part number 653888 or 653906 lifters are present, the engine is not affected by this MSB.
 - a. Re-install the lifters according to the Hydraulic Lifter Installation instructions in Section B, leak check, and return the engine to service.
 - b. Make an engine logbook entry indicating “MSB09-8 inspection complied with. No TCM Part No. 657913, 657915, or 657916 lifters installed on engine.”
3. If 657915 or 657916 lifters are found, proceed to Step 2.

ISSUE DATE	REVISION DATE	 PO BOX 90, Mobile, AL 36601 251-438-3411	PAGE NO	REVISION
03 Nov 2009	04 Dec 2009			2 of 19
			MSB09-8	

For engines that have been repaired or overhauled using part number 657913, 657915, or 657916 lifters:

1. Determine location of and number of lifters installed. If the location cannot be determined, all lifters must be removed for verification according to instructions in Section B.
2. If 657913, 657915 or 657916 lifters are verified, proceed to Step 2.

Step 2.

For any engine with 657913, 657915, or 657916 lifters installed:

1. Remove intake lifters only for any engine listed in Section A that does not have an “EX” in the column next to the Serial number. For those engines with an “EX” beside the serial number, both intake and exhaust lifters should be removed for inspection. For engines repaired or overhauled in the field, remove all lifters for examination according to the Hydraulic Lifter Removal instructions in Section B.
2. Compare the face condition to the photographs in the Comparison Photos section.
 - a. If no indications similar to the abnormal condition photos are found:
 - 1) Replace the lifters according to the Hydraulic Lifter Installation instructions in Section B with new or serviceable lifters of **TCM part numbers 628488, 646277, 653877, 653888, 653906 or 658024, 658026, 658027 lifters, (as applicable to the engine model)**, leak check, and return the engine to service.
 - 2) Complete the Lifter Return Form on page 19 and contact TCM Customer Service at the phone number listed on page 7 to obtain a return authorization. Drain the oil from the lifters and pack each lifter individually in a zip lock bag, identifying the cylinder position and engine serial number from which the lifter was removed on the outside of the bag. Pack the individually bagged lifters in a larger zip lock bag identified with the engine serial number on the outside bag. Submit the completed Lifter Return Form on page 19, along with the removed lifters.
 - 3) Make an engine log book entry indicating the method of compliance with MSB09-8, for example: “MSB09-8 inspection complied with; identified and replaced (*quantity*) TCM Part No. 657913, 657915, or 657916 lifters with TCM Part No. 628488, 646277, 653877, 653888, 653906 or 658024, 658026, 658027 (as applicable) lifters.”

WARNING

DO NOT PLACE OR RETURN ANY 657913, 657915 OR 657916 LIFTERS IN SERVICE

- b. If the lifter face inspection reveals indications similar to those depicted in Figure 2 through Figure 5, or if any of the removed lifters exhibits unusual wear, spalling galling, or nicks:

ISSUE DATE	REVISION DATE	 PO BOX 90, Mobile, AL 36601 251-438-3411	PAGE NO	REVISION
03 Nov 2009	04 Dec 2009		3 of 19	A
			MSB09-8	

- 1) Inspect the associated cam lobe with a borescope using the instructions contained in SID05-1.
- 2) Remove the oil filter or screen. Clean and reinstall the reusable oil screen and change the engine oil according to the engine servicing instructions. Replace the disposable oil filter and change the engine oil according to the engine servicing instructions.
- 3) If cam lobes are normal:
 - a) Replace the lifters according to the Hydraulic Lifter Installation instructions in Section B with new or serviceable lifters of **TCM part numbers 628488, 646277, 653877, 653888, 653906 or 658024, 658026, 658027 lifters, (as applicable to the engine model)**, leak check, and return the engine to service.
 - b) Conduct a ground engine run and leak check and return the engine to service.
 - c) Complete the Lifter Return Form on page 19 and contact TCM Customer Service at the phone number listed on page 7 to obtain a return authorization. Drain the oil from the lifters and pack each lifter individually in a zip lock bag, identifying the cylinder position and engine serial number from which the lifter was removed on the outside of the bag. Pack the individually bagged lifters in a larger zip lock bag identified with the engine serial number on the outside bag. Submit the completed Lifter Return Form on page 19, along with the removed lifters.
 - d) Make an entry in the engine log book indicating the method of compliance with MSB09-8, for example: “MSB09-8 inspection complied with; identified and replaced (*quantity*) TCM Part Nos. 657913, 657915, or 657916 lifters with TCM Part Nos. 653877, 653888, 653906 or 658024, 658026, 658027 (as applicable) lifters. No discrepancies noted in camshaft condition.”
- 4) If the cam lobes are distressed, contact TCM Customer Service using the phone numbers on page 7 for authorization to return the engine to TCM for repair.

ISSUE DATE	REVISION DATE	 PO BOX 90, Mobile, AL 36601 251-438-3411	PAGE NO	REVISION
03 Nov 2009	04 Dec 2009			4 of 19 MSB09-8

II. COMPARISON PHOTOS OF HYDRAULIC LIFTERS

Abnormal Wear, Reduced Height

Normal Wear



Figure 2. Wear Comparisons

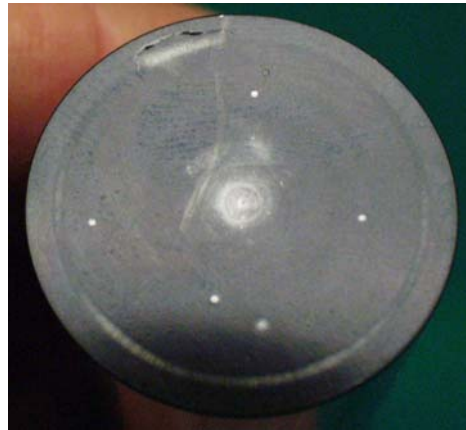

Figure 3. Crack in Lifter Face, Abnormal Condition



Figure 4. Pitted Surface on Lifter Face, Abnormal Condition

ISSUE DATE	REVISION DATE	 PO BOX 90, Mobile, AL 36601 251-438-3411	PAGE NO	REVISION
03 Nov 2009	04 Dec 2009			5 of 19
			MSB09-8	



Figure 5. Spalling on Lifter Face, Abnormal Condition

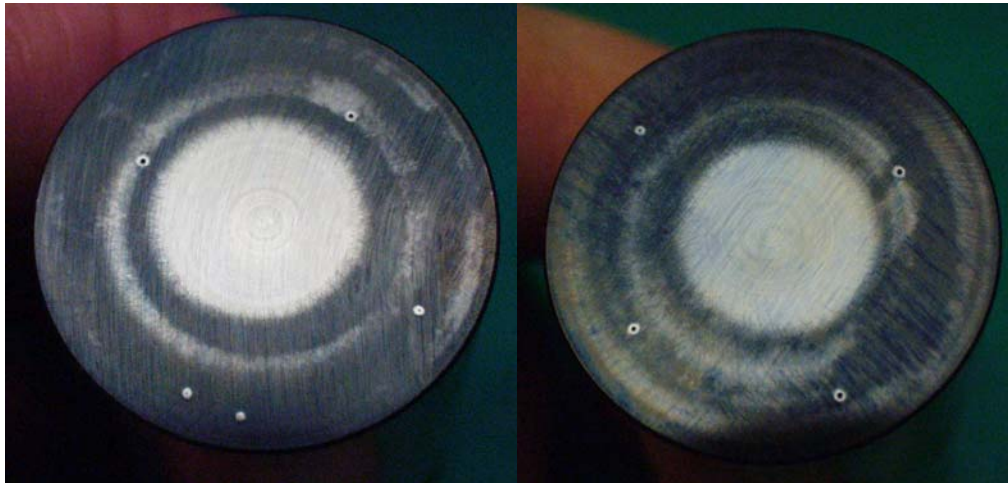



Figure 6. Normal Lifter Face Wear Patterns

ISSUE DATE	REVISION DATE	 PO BOX 90, Mobile, AL 36601 251-438-3411	PAGE NO	REVISION
03 Nov 2009	04 Dec 2009		6 of 19	A
		MSB09-8		

III. TCM CONTACT INFORMATION

TCM Customer Service Department: 1-888-826-5465 for Continental U.S.
1-251-438-3411 International callers

TCM shipping address:

Teledyne Continental Motors
Analytical Department Attn: Lifter Return
2039 Broad Street
Mobile, AL 36615

IV. WARRANTY

TCM will pay reasonable labor costs to complete the inspection of engines affected by this service bulletin. TCM will pay for necessary parts, consumable supplies and reasonable labor costs for the engines designated in this service bulletin to remove and replace hydraulic lifter part numbers 657913, 657915 or 657916 and associated repairs required as a result of installation of said hydraulic lifter part numbers to return the engine to service.

TCM has made special arrangements with a number of authorized alternate suppliers to ensure availability of replacement lifters for affected engines. TCM will reimburse procurement costs for the parts and supplies obtained through these authorized alternate suppliers. Please refer to www.genuinecontinental.aero for specific instructions regarding these arrangements and replacement parts.

ISSUE DATE	REVISION DATE	 PO BOX 90, Mobile, AL 36601 251-438-3411	PAGE NO	REVISION
03 Nov 2009	04 Dec 2009		7 of 19	A
		MSB09-8		

Section A. Serial Number List

Engine Serial Number	Engine Model
NOTE: "R-" prefix indicates rebuilt. "EX" suffix indicates both the intake and exhaust lifter inspection is required.	
1000285	R-I0550B38B
1000395	R-0470U13B
1000423	R-I0520F64B
1000499	R-TSI0520T1B
1000540	R-0470U18B
1000541	R-0470R74B
1000547	R-GTSI0520M2B
1000589	R-I0550D15B
1000592	TSI0520R9B
1000607	I0550D1B
1000613	R-I0520D116B
1000616	I0550B39B
1000617	I0550B39B
1000620	I0550N60B
1000621	I0550N60B
1000623	I0550N60B
1000624	I0550N60B
1000627	I0550N61B
1000628	I0550N61B
1000629	I0550N61B
1000631	I0550N61B
1000632	TSI0550E16B
1000634	R-I0470L21B
1000635	R-I0520D24B
1000636	R-I0520F16B
1000638	I0520D26B
1000639	I0550B1F
1000641	R-0470U18B
1000642	R-I0550D24B
1000643	R-I0550D27B
1000644	TSI0520UB4F
1000647	R-TSI0520R9B
1000648	R-TSI0520VB10F
1000650	I0520F17B
1000651	I0550B39B
1000652	I0550F21B
1000655	R-0470R74B
1000657	I0550N60B
1000662	I0550N61B
1000663	R-I0470V09B
1000664	R-I0550B38B
1000665	R-I0550B77B
1000666	R-I0550B82B
1000670	I0520L13B

Engine Serial Number	Engine Model
NOTE: "R-" prefix indicates rebuilt. "EX" suffix indicates both the intake and exhaust lifter inspection is required.	
1000671	R-I0520F64B
1000673	R-TSI0520VB9F
1000678	I0550N60B
1000679	I0550N60B
1000681	I0550N61B
1000682	I0550N61B
1000683	I0550N61B
1000684	R-I0520MB1B
1000685	R-I0520MB1B
1000686	R-I0550B1F
1000687	R-TSI0520EB8B
1000688	R-I0550C2F
1000689	R-I0550C2F
1000697	R-I0550B89B
1000698	R-I0550B89B
1000699	R-TSI0520C3B
1000700	I0520D111B
1000702	I0550N60B
1000704	I0550N60B
1000706	I0550N61B
1000709	R-I0520D113B
1000710	R-TSI0520VB10F
1000711	R-TSI0520VB10F
1000712	TSI0520T1B
1000714	R-TSI0520VB9F
1000715	R-I0520CB8B
1000716	I0550B39B
1000717	I0550C31B
1000718	R-TSI0520VB10F
1000719	R-TSI0520VB10F
1000720	R-TSI0520VB9F
1000724	R-I0550B89B
1000725	R-I0550C47B
1000726	R-I0550C47B
1000727	R-TSI0520T1B
1000728	R-TSI0520T1B
1000730	R-I0470L21B
1000731	R-I0520BB6B
1000732	R-I0520CB3B
1000733	R-I0520CB3B
1000734	R-I0520D30B
1000737	R-0470S1B
1000746	R-I0550D15B
1000747	TSI0520M7B

ISSUE DATE	REVISION DATE	 PO BOX 90, Mobile, AL 36601 251-438-3411	PAGE NO	REVISION
03 Nov 2009	04 Dec 2009			8 of 19 MSB09-8

Engine Serial Number	Engine Model
NOTE: "R-" prefix indicates rebuilt. "EX" suffix indicates both the intake and exhaust lifter inspection is required.	
1000748	I0550C31B
1000751	I0550N60B
1000755	I0550N61B
1000757	R-I0550P3B
1000758	R-TSI0520AE3B
1000760	I0550B39B
1000761	R-GTSI0520L3B
1000763	R-TSI0520VB10F
1000764	I0550B39B
1000773	I0520L46B
1000776	I0550N8B
1000778	0470U18B
1000786	I0550N61B
1000788	R-I0550D13B
1000789	R-TSI0520CE1F
1000790	I0520F9B
1000791	R-0470R25U
1000793	R-I0520A32B
1000794	R-I0520F64B
1000795	R-I0520L46B
1000796	R-I0550B4F
1000797	R-I0550G6B
1000798	R-I0550N56B
1000799	R-I0550N54B
1000803	R-0470R76B
1000804	R-I0520L59B
1000805	R-I0550B89B
1000806	R-TSI0520VB1B
1000807	R-TSI0520VB2B
1000808	I0550B1F
1000809	I0550B39B
1000810	I0550F21B
1000811	R-I0520C7B
1000812	R-I0550B89B
1000813	R-I0550F40B
1000817	R-TSI0520VB10F
1000818	R-TSI0520VB9F
1000819	R-TSI0520VB9F
1000820	I0550C70B
1000821	I0550C70B
1000822	I0520F9B
1000823	I0520L8B
1000824	I0550E3B
1000825	I0550N61B
1000827	R-I0520F64B
1000831	R-I0550D15B

Engine Serial Number	Engine Model
NOTE: "R-" prefix indicates rebuilt. "EX" suffix indicates both the intake and exhaust lifter inspection is required.	
1000832	R-TSI0520C3B
1000835	R-0470R74B
1000836	R-I0520BB83B
1000837	R-I0520BB83B
1000838	R-I0520BB83B
1000839	R-I0520BB83B
1000840	R-I0520CB41B
1000841	0470R25F
1000842	I0550B39B
1000843	I0550C31B
1000847	R-0470U18B
1000848	R-I0520D172B
1000849	R-I0520L46B
1000850	R-I0550D27B
1000851	R-I0550D27B
1000852	R-TSI0520VB10F
1000853	R-TSI0520VB9F
1000854	TSI0520R9B
1000856	R-TSI0520VB4F
1000857	R-TSI0520VB4F
1000858	I0520F12B
1000860	R-I0520F12B
1000861	R-TSI0520UB4F
1000862	TSI0520P6B
1000863	I0520D111B
1000864	I0520D111B
1000865	I0550B39B
1000868	R-0470R74B
1000870	R-I0520CB8B
1000878	I0520D90B
1000879	I0550B1F
1000881	I0550B39B
1000882	I0550B39B
1000883	I0550C31B
1000884	I0550C31B
1000885	I0550N27B
1000886	I0550N38B
1000893	R-0470R74B
1000894	R-0470S1B
1000896	I0550B82B
1000902	TSI0520AE2B
1000903	TSI0520UB2F
1000904	TSI0520UB3F
1000905	R-I0470D56B
1000906	R-I0470L21B
1000907	R-TSI0520EB9B

ISSUE DATE	REVISION DATE	 PO BOX 90, Mobile, AL 36601 251-438-3411	PAGE NO	REVISION
03 Nov 2009	04 Dec 2009		9 of 19	A
			MSB09-8	

Engine Serial Number	Engine Model
NOTE: "R-" prefix indicates rebuilt. "EX" suffix indicates both the intake and exhaust lifter inspection is required.	
1000908	R-I0470L28B
1000909	R-I0470S11B
1000910	R-TSI0520M7B
1000911	R-TSI0520VB1F
1000912	R-I0520B6B
1000913	R-I0520CB9F
1000914	R-I0520CB9F
1000915	R-I0520D116B
1000916	R-I0520D139B
1000917	R-I0520F3B
1000918	R-I0520K1B
1000919	R-0470R74B
1000922	TSI0520M7B
1000923	TSI0520M7B
1000924	TSI0520M7B
1000925	R-I0520L46B
1000926	R-I0520MB1B
1000927	R-I0520MB1B
1000928	R-I0520MB1B
1000929	R-I0520MB1B
1000930	R-I0520MB1B
1000931	R-I0550B38B
1000932	R-I0550C3F
1000933	R-I0550C71B
1000934	R-I0550C71B
1000935	R-I0550C71B
1000936	R-I0550C71B
1000937	R-I0550C71B
1000938	R-I0550C71B
1000944	I0550B39B
1000946	R-GTSI0520H1B
1000947	R-GTSI0520H2B
1000948	R-GTSI0520M2B
1000950	R-I0550C47B
1000951	R-I0550F5B
1000952	R-I0520F13B
1000953	R-I0520F27B
1000954	I0550C65B
1000959	R-TSI0520VB9F
1000960	R-TSI0520VB9F
1000961	R-TSI0520VB9F
1000962	R-TSI0520E19B
1000965	R-I0470L21B
1000966	R-I0470L21B
1000967	R-I0520M1B
1000968	R-I0550F21B

Engine Serial Number	Engine Model
NOTE: "R-" prefix indicates rebuilt. "EX" suffix indicates both the intake and exhaust lifter inspection is required.	
1000969	R-TSI0520VB1B
1000970	R-I0520L59B
1000971	I0520L13B
1000972	I0550B39B
1000973	I0550B39B
1000974	I0550B82B
1000975	I0550C31B
1000976	I0550C31B
1000978	R-I0520BB74B
1000979	R-TSI0520R9B
1000997	R-I0520F6B
1000999	I0520BB10B
1001000	0470R25B
1001002	R-TSI0520WB3F
1001003	R-TSI0520WB3F
1001005	I0550C31B
1001007	I0550N61B
1001008	R-I0520F27B
1001009	R-TSI0520R9B
1001010	R-TSI0520VB10F
1001011	R-TSI0520VB10F
1001012	R-TSI0520VB9F
1001013	TSI0520M7B
1001014	R-I0520C15B
1001015	R-I0520F17B
1001016	R-I0550L12B
1001018	R-I0550D15B
1001021	I0550N61B
1001022	I0550N61B
1001023	R-I0470L23B
1001036	I0550N61B
1001038	I0550N61B
1001042	R-I0520F27B
1001045	R-I0520F16B
1001046	EX R-LTSI0360EB1B
1001048	R-I0550C33B
1001049	R-I0550C33B
1001051	R-TSI0520E4B
1001052	R-I0520F27B
1001053	R-I0550B127B
1001054	0470U13B
1001055	R-I0550D20B
1001056	R-TSI0520BE2G
1001057	R-TSI0520C6B
1001059	I0550N54B
1001060	I0550N42B

ISSUE DATE	REVISION DATE	 PO BOX 90, Mobile, AL 36601 251-438-3411	PAGE NO	REVISION
03 Nov 2009	04 Dec 2009		10 of 19	A
			MSB09-8	

Engine Serial Number	Engine Model
NOTE: "R-" prefix indicates rebuilt. "EX" suffix indicates both the intake and exhaust lifter inspection is required.	
1001061	I0550N42B
1001062	I0550N42B
1001063	I0550N42B
1001069	R-I0550L11B
1001075	R-I0550F40B
1001084	R-TSI0520M7B
1001085	I0520D26B
1001086	R-I0520F3B
1001087	R-I0550D27B
1001092	R-I0550D24B
1001093	R-I0550D24B
1001094	R-I0520D112B
1001095	I0520BB16B
1001096	R-I0520A5B
1001097	TSI0520C6B
1001098	R-TSI0550C14B
1001101	I0550N19B
1001102	LTSI0520AE3B
1001103	R-0470S2K
1001104	TSI0520R9B
1001105	I0520F64B
1001108	R-I0520D116B
1001109	R-I0470L21B
1001110	R-I0520L47B
1001112	R-TSI0520VB10F
1001113	R-TSI0520VB9F
1001114	R-TSI0520VB9F
1001119	R-I0550B89B
1001120	R-I0520F43B
1001121	R-I0520F6B
1001122	R-I0520E2B
1001124	R-TSI0520EB9B
1001125	R-I0550D13B
1001127	R-I0470L21B
1001128	R-I0470L21B
1001129	R-I0520D35B
1001133	I0550C70B
1001134	I0550C70B
1001135	I0550C70B
1001136	I0550C70B
1001138	I0520F12B

Engine Serial Number	Engine Model
NOTE: "R-" prefix indicates rebuilt. "EX" suffix indicates both the intake and exhaust lifter inspection is required.	
1001141	R-I0520CB31B
1001142	R-I0550P3B
1001145	R-GTSI0520M2B
1001146	EX R-TSI0360EB1B
1001147	R-TSI0520R9B
1001149	R-0470S2B
1001150	R-I0470V09B
1001151	R-I0520F27B
1001152	R-I0520F43B
1001153	R-I0550B75B
1001155	R-TSI0520M7B
1001157	EX TSI0360RB1B
1001158	R-0470R25B
1001159	R-I0520F83B
1001160	R-I0520D40B
1001161	R-I0550F37B
1001162	R-0470U17B
1001163	0470R78B
1001164	R-I0520BB15B
1001165	R-I0470L21B
1001172	R-I0550C71B
1001174	I0550D15B
1001175	R-I0550B82B
1001177	EX R-TSI0360LB1B
1001187	EX R-TSI0360FB1B
1001188	R-I0520CB36B
1001189	R-0470S2B
1001191	R-I0520BB6B
1001193	R-I0520BB15B
1001194	R-I0520C7B
1001195	R-I0520C7B
1001197	EX R-I0360GB3B
1001200	R-I0520F12B
1001202	I0550B4F
1001210	R-0470R74B
1001213	I0550C31B
1001236	EX TSI0360EB1B

ISSUE DATE	REVISION DATE	 PO BOX 90, Mobile, AL 36601 251-438-3411	PAGE NO	REVISION
03 Nov 2009	04 Dec 2009			11 of 19 MSB09-8

Section B. Removal and Installation Instructions

WARNING

Turn the Ignition Switch to the OFF position and disconnect engine electrical power prior to commencing maintenance. Do not stand or place equipment within the rotational arc of the propeller.

B.1. Hydraulic Lifter Removal

B.1.a. Updraft Cylinder Lifter Removal

NOTE: Remove only those components related to the “Intake” valve train unless exhaust lifter inspection is required as indicated in Step 2, paragraph 1.

1. Remove cowling and any airframe supplied accessories in accordance with the airframe manufacturer's instructions to gain access to the cylinder.
2. Disconnect the battery according to the airframe manufacturer's instructions.
3. Disconnect all spark plug leads and remove the upper spark plug from each cylinder.
4. Remove the rocker cover fasteners and rocker covers from the cylinder.
5. Remove and discard the rocker cover gaskets.
6. Position the crankshaft so the piston is at top dead center and both intake and exhaust valves of the cylinder being disassembled are closed.
7. Remove the screws and washer from the rocker arm bosses.
8. Bleed the hydraulic lifters down by applying steady pressure to the pushrod end of the rocker arm; lifter pressure relief should be obvious.
9. Remove the rocker shafts, rocker arms and thrust washers from the rocker arm bosses.
10. Withdraw all of the push rods from their respective housings. Mark the location and position of removal to ensure installation in the same position and location.
11. Compress each push rod housing spring with a Pushrod Spring Compressor Tool. While the spring is compressed, push the outboard end of the pushrod housing away from the cylinder head; lower the outboard end of the pushrod housing down and away from the cylinder. Remove the push rod housing, springs, washers and packing.
12. Discard the packing.
13. Remove the hydraulic lifters from the crankcase lifter bores. Identify the location and position of removal. Serviceable lifters shall be returned (as applicable) to the same cylinder position and location from which they were removed.
14. If the lifter cannot be removed easily from the lifter bore, do not force removal; contact TCM for further instructions.

ISSUE DATE	REVISION DATE	 PO BOX 90, Mobile, AL 36601 251-438-3411	PAGE NO	REVISION
03 Nov 2009	04 Dec 2009		12 of 19	MSB09-8

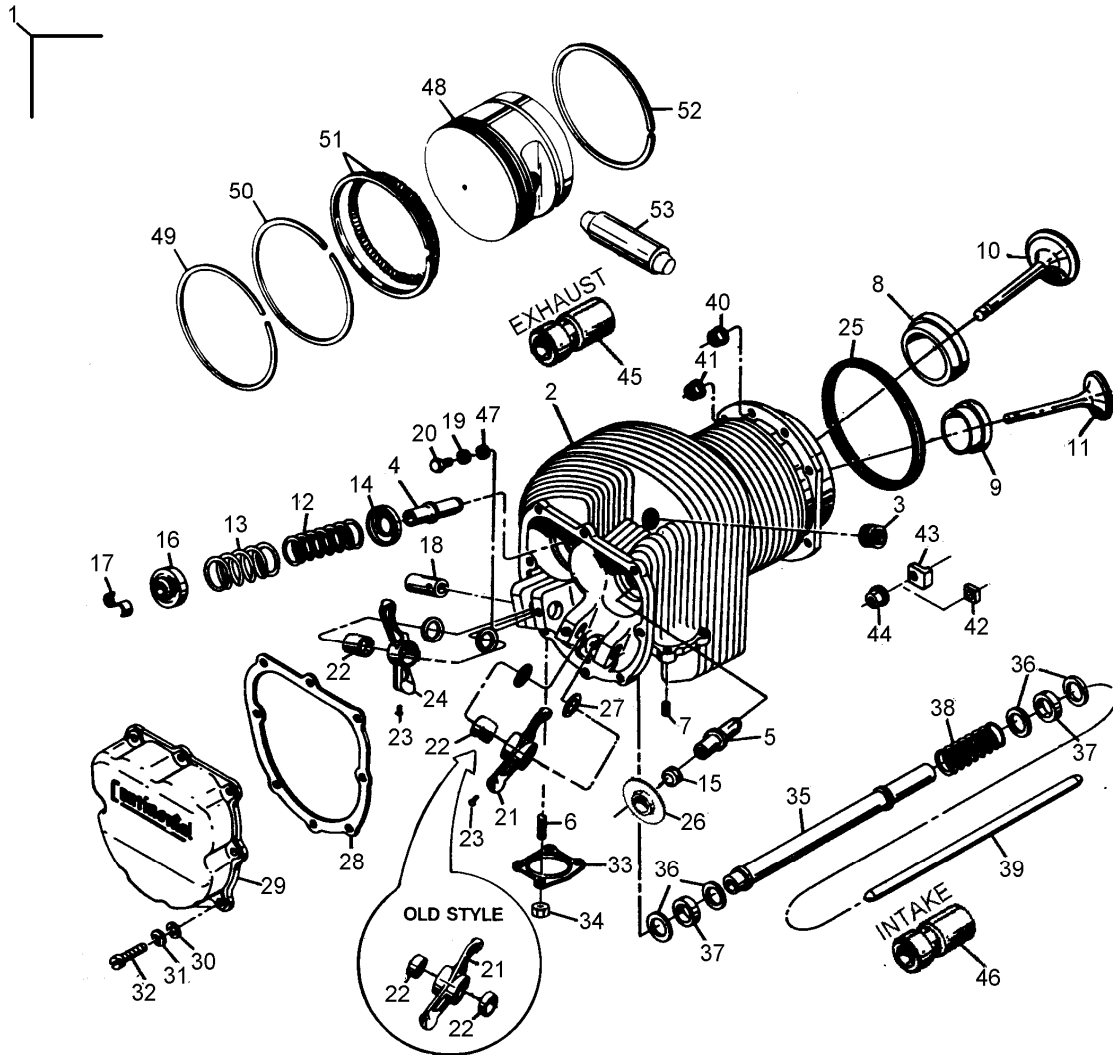



Figure 7. Updraft Cylinder Assembly

1	Cylinder Assembly	15	Seal	29	Valve Rocker Cover	43	7 th . Stud Bracket
2	Cylinder	16	Rotocoil	30	Washer	44	Flange Nut
3	Spark Plug Insert	17	Retainer Key	31	Lock Washer	45	Hydraulic Exhaust Lifter
4	Valve Exhaust Guide	18	Valve Rocker Shaft	32	Screw	46	Hydraulic Intake Lifter
5	Intake Guide	19	Plain Washer	33	Exhaust Flange Gasket	47	Helical Coil Insert
6	Stud	20	Screw	34	Nut	48	Piston
7	Intake Flange Insert	21	Rocker Arm, Intake	35	Push Rod Housing	49	Compression Ring
8	Intake Valve Seat	22	Valve Rocker Arm Bushing	36	Washer	50	Compression Ring
9	Exhaust Valve Seat	23	Drive Screw	37	Packing	51	Oil Control Ring
10	Intake Valve	24	Rocker Arm Exhaust	38	Spring	52	Scraper Ring
11	Exhaust Valve	25	Cylinder Base O-ring	39	Push Rod	53	Piston Pin
12	Inner Spring	26	Intake Valve Retainer	40	Flange Nut		
13	Outer Spring	27	Thrust Washer	41	Flange Nut		
14	Lower Retainer	28	Rocker Cover Gasket	42	7 th . Stud Bracket		

ISSUE DATE	REVISION DATE	 PO BOX 90, Mobile, AL 36601 251-438-3411	PAGE NO	REVISION
03 Nov 2009	04 Dec 2009			13 of 19
			MSB09-8	

B.1.b. Crossflow Cylinder Lifter Removal

NOTE: Remove only those components related to the “Intake” valve train unless exhaust lifter inspection is required as indicated in Step 2, paragraph 1.

1. Remove cowling and any airframe supplied accessories according to the airframe manufacturer's instructions to gain access to the cylinder.
2. Disconnect the battery according to the airframe manufacturer's instructions.
3. Disconnect all spark plug leads and remove the upper spark plug from each cylinder.
4. Remove the rocker cover fasteners and rocker covers from the cylinder.
5. Remove and discard the rocker cover gaskets.
6. Position the crankshaft so the piston is at top dead center and both intake and exhaust valves of the cylinder being disassembled are closed.
7. Remove the rocker shaft retention screw (nuts for 240/360), tab washer and retainer from the rocker arm bosses; discard the tab washers.
8. Bleed the hydraulic lifters down by applying steady pressure to the pushrod end of the rocker arm; lifter pressure relief should be obvious.
9. Remove the rocker shafts, rocker arms, and thrust washers from the cylinders.
10. Withdraw all of the push rods from their respective housings. Mark the location and position of removal to ensure installation in the same position and location.
11. Compress each push rod housing spring with a Pushrod Spring Compressor Tool. While the spring is compressed, push the outboard end of the pushrod housing away from the cylinder head, lower the outboard end of the pushrod housing down and away from the cylinder. Remove the push rod housing, springs, washers, O-ring, and packing.
12. Discard the O-ring and packing.
13. Remove the hydraulic lifters from the crankcase lifter bores. Identify the location and position from which the lifters are removed. Serviceable lifters shall be returned (as applicable) to the same cylinder position and location from which they were removed.
14. If the lifter cannot be removed easily from the lifter bore, do not force removal; contact TCM for further instructions.

ISSUE DATE	REVISION DATE	 PO BOX 90, Mobile, AL 36601 251-438-3411	PAGE NO	REVISION
03 Nov 2009	04 Dec 2009		14 of 19	MSB09-8

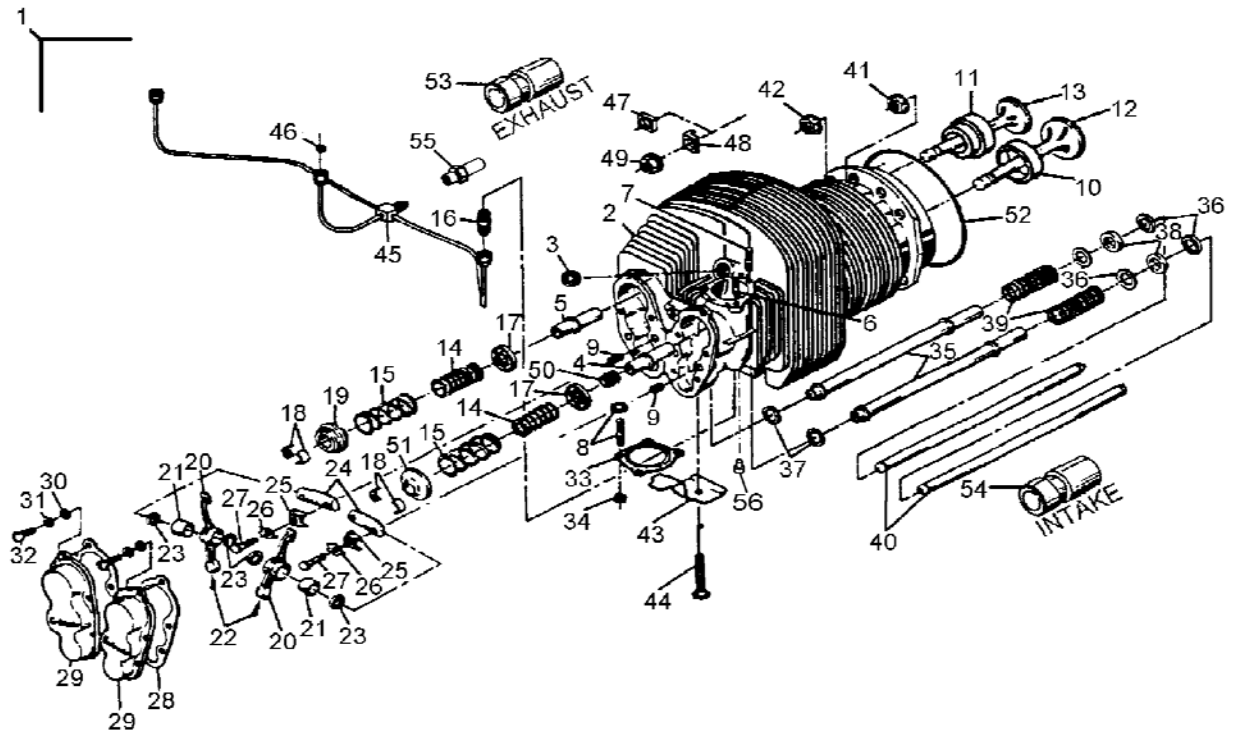



Figure 8. Crossflow Cylinder Assembly

- | | | | | | | | |
|----|----------------------|----|----------------------|----|-----------------------|----|--------------------------------|
| 1 | Cylinder Assembly | 15 | Outer Spring | 29 | Valve Rocker Cover | 43 | Baffle |
| 2 | Cylinder | 16 | Drain Tube Fittings | 30 | Washer | 44 | Spring |
| 3 | Spark Plug Insert | 17 | Lower Retainer | 31 | Lock Washer | 45 | Drain Tube |
| 4 | Intake Guide | 18 | Retainer Key | 32 | Screw | 46 | Drain Tube Seals |
| 5 | Valve Exhaust Guide | 19 | Rotocoil | 33 | Exhaust Flange Gasket | 47 | 7 th . Stud Bracket |
| 6 | Stud | 20 | Rocker Arms | 34 | Nut | 48 | 7 th . Stud Bracket |
| 7 | Stud | 21 | Valve Rocker Bushing | 35 | Push Rod Housing | 49 | Flange Nut |
| 8 | Stud | 22 | Drive Screw | 36 | Washer | 50 | Seal |
| 9 | Helical Coil Insert | 23 | Thrust Washer | 37 | O-Ring Seal | 51 | Retainer |
| 10 | Intake Valve Insert | 24 | Valve Rocker Shaft | 38 | Packing | 52 | Cylinder Base O-Ring |
| 11 | Exhaust Valve Insert | 25 | Retainer | 39 | Spring | 53 | Hydraulic Exhaust Lifter |
| 12 | Intake Valve | 26 | Tab Washers | 40 | Push Rod | 54 | Hydraulic Intake Lifter |
| 13 | Exhaust Valve | 27 | Screw | 41 | Flange Nut | | |
| 14 | Inner Spring | 28 | Rocker Cover Gaskets | 42 | Flange Nut | | |

ISSUE DATE	REVISION DATE	 PO BOX 90, Mobile, AL 36601 251-438-3411	PAGE NO	REVISION
03 Nov 2009	04 Dec 2009			15 of 19
			MSB09-8	

B.2. Hydraulic Lifter Installation

1. Liberally lubricate all replacement lifter faces using Molykote, Dow Corning® G-N Paste, or equivalent. Lubricate the lifter bodies with clean 50-weight aviation engine oil.

NOTE: Forward refers to the crankshaft end of the engine; aft refers to the accessory end of the engine.

2. Install any unaffected hydraulic lifters in the bores from which they were removed. Install replacement hydraulic lifters to replace those affected by this bulletin.
3. Install hydraulic *exhaust* lifters into the *aft* lifter bores in cylinders on the 1-3-5 side of the crankcase and in the *forward* lifter bores for cylinders on the 2-4-6 side of the crankcase.
4. Install hydraulic *intake* lifters into the *forward* lifter bores in cylinders on the 1-3-5 side of the crankcase and in the *aft* lifter bores for cylinders on the 2-4-6 side of the crankcase.
5. Using a Pushrod Spring Compressor (or equivalent), compress the pushrod housing spring.
6. Place a new packing between the two steel washers, and install on the crankcase end of the pushrod housing.
7. Position the pushrod housings into respective ports on the crankcase.
8. While the spring is compressed and the housing is installed in the crankcase, slide a new packing (O-Ring for Crossflow cylinders), sandwiched between the two steel washers on the cylinder end of the pushrod housing.
9. Guide the cylinder end of the pushrod housing into the cylinder head bore while releasing the pushrod spring tension with the Pushrod Spring Compressor Tool.
10. Remove the Pushrod Spring Compressor Tool from the pushrod and verify the packing and washers are properly positioned.
11. Lubricate the pushrods with clean 50-weight aviation engine oil and install the pushrods through the cylinder openings into the pushrod housings.
12. Before installing the rocker arms on each cylinder, position the crankshaft so the pushrods are at their lowest position in the pushrod tube, the piston is at top dead center and both the intake and exhaust lobes on the camshaft are facing away from the rocker arms.
13. With the piston at top dead center of the compression stroke, bleed down the lifter by applying a constant pressure on the pushrod end of the rocker arm.

NOTE: Instructions vary slightly for updraft and crossflow cylinder designs. For crossflow cylinders, proceed to step 15, updraft cylinders continue with the next step.

ISSUE DATE	REVISION DATE	 PO BOX 90, Mobile, AL 36601 251-438-3411	PAGE NO	REVISION
03 Nov 2009	04 Dec 2009			16 of 19 MSB09-8

14. Updraft Cylinder Rocker Shaft Installation:

- a. Lubricate the rocker shafts with clean 50-weight aviation engine oil. Install the rocker arms with one thrust washer on each side of the rocker shaft and center the rocker shaft in the boss. Insert the rocker shafts (non-chamfered end first) in the rocker shaft boss, rotate the rocker shaft in the bore to position the chamfer closest to the cylinder.
- b. Check rocker arm side clearance between the boss and rocker arms with a feeler gauge; side clearance must be 0.002 - 0.015 inches. If side clearance exceeds the allowable amount, replace the thrust washers with a thicker (oversize) thrust washer to reduce side clearance to the correct tolerance.

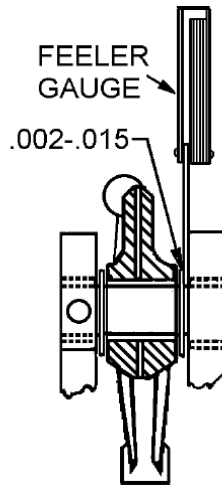



Figure 9. Updraft Cylinder Rocker Arm Side Clearance

- c. Install rocker shaft bolts, lock washer and flat washer; torque the bolt to 90-100 inch pounds.
- d. Measure the dry valve lash at valve tip-to-rocker foot by applying pressure on the rocker arm at the ball (pushrod) end. Insert a feeler gauge between the rocker arm foot and valve tip; allowable limits are 0.060 (min) to 0.200 (max). Replace the pushrods with authorized over size pushrods (P030) if the dry valve lash exceeds the maximum limit.

NOTE: For updraft cylinders, proceed to step 16, crossflow cylinders continue with the next step.

15. Crossflow Cylinder Rocker Shaft Installation:

- a. Lubricate the rocker shafts with clean 50-weight aviation engine oil and insert the rocker shafts in the rocker arms. Place a new thrust washer on each side of the rocker arm and center the rocker arm and thrust washers on the shaft.
- b. Align the rocker shaft screw holes with the rocker boss; install the screws (nuts on 240/360 engines) with new tab washers and retainers. Torque the screws for all 470, 520 and 550 series engines 190-210 inch pounds. Torque the nuts on 240/360 series engines 110-120 inch pounds.

ISSUE DATE	REVISION DATE	 PO BOX 90, Mobile, AL 36601 251-438-3411	PAGE NO	REVISION
03 Nov 2009	04 Dec 2009			17 of 19
			MSB09-8	

- c. Check rocker arm side clearance between the retainers and rocker arms with a feeler gauge; side clearance must be 0.002 - 0.015 inches. If side clearance exceeds the allowable amount, replace the thrust washers with a thicker (oversize) thrust washer to reduce side clearance to the correct tolerance.
- d. Measure the dry valve lash at valve tip-to-rocker foot by applying pressure on the rocker arm at the ball (pushrod) end. Insert a feeler gauge between the rocker arm foot and valve tip; allowable limits are 0.060 (min) to 0.200 (max). Replace the pushrods with authorized over size pushrods (P030) if the dry valve lash exceeds the maximum limit.
- e. If all measurements are correct, verify rocker arm fastener torque and secure the rocker arm screws (nuts on 240/360 engines) by bending the new tab washer tabs against the flat side of the screw heads (nuts on 240/360 engines).

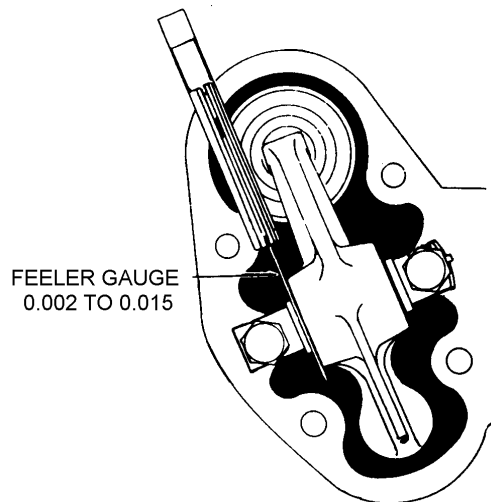



Figure 10. Crossflow Cylinder Rocker Arm Side Clearance

- 16. Install the rocker cover with new rocker cover gasket; secure with screws, new lock washers and flat washers.

ISSUE DATE	REVISION DATE	 PO BOX 90, Mobile, AL 36601 251-438-3411	PAGE NO	REVISION
03 Nov 2009	04 Dec 2009			18 of 19
			MSB09-8	



CONTINENTAL MOTORS MSB09-8 Lifter Return Form

Failure to complete form and return lifters will result in delay of warranty processing.

Engine Serial Number _____

Lifter part number(s) returned:

657913: Number of affected lifters _____ Number of unused lifters _____

657915: Number of affected lifters _____ Number of unused lifters _____

657916: Number of affected lifters _____ Number of unused lifters _____

Engine hours: _____

Name of person performing inspection: _____

Maintenance Facility _____

Address _____

City _____ State _____ Postal Code _____

Phone _____ Email _____

Man hours to perform exchange: _____

Posted shop rate: _____

Oil: _____

Filter: _____ **Signature:** _____

Send Reimbursement Payment to above address (or complete below)

Name _____

Address _____

City _____ State _____ Postal Code _____

Phone _____ Email _____

Ship affected and unused lifters to:

Include this form in the box and attach label clearly to the outside of box. Please ensure the lifters are packaged and labeled to indicate the cylinder position from which they were removed.

Teledyne Continental Motors
Attn: MSB09-8
Analytical Department
2039 Broad Street
Mobile, Alabama 36615

FEDEX Account: 488384201
Mark Airway Bill: "Warranty Engine Parts"

TCM Use Only:

_____ Man hours x \$ _____ approved shop rate + \$ _____ misc. = \$ _____ Total

TCM approval: _____